

# Theory of Constraints Project Management

---

*A Brief Introduction to the Basics*



Copyright ©1996-2009 Avraham Y. Goldratt Institute, LP. All rights reserved. This paper may be downloaded, reproduced and distributed. However, distribution of this paper to the public by sale, rental or lease is strictly prohibited. This paper shall not be used as part of or incorporated into any other written work or publication except with the written permission of the Avraham Y. Goldratt Institute, LP. No derivative works may be created based on this paper except with the written permission of the Avraham Y. Goldratt Institute, LP.

## TABLE OF CONTENTS.

INTRODUCTION.....	3
THE MAIN ROOTS.....	4
IDENTIFYING “WHAT TO CHANGE?”	
THE SOLUTION FOR THE MAIN ROOTS.....	5
IDENTIFYING “WHAT TO CHANGE TO?”	
PUTTING THE SOLUTION INTO PLACE.....	11
IDENTIFYING “HOW TO CAUSE THE CHANGE?”	

*When one thinks of project environments, they mainly think of construction, engineering, technology development, and telecommunications. But, more than ever, non-traditional project environments expect their managers to be capable of managing projects and programs. Why?*

*Execution – the ability to execute to plan - is essential to creating competitive advantage. More than ever, to execute to plan is to properly manage the TIME value of money and resources.*

*In many for-cause organizations, the key to continued support of its benefactors is the stewardship of funds leading to the successful completion of projects that are of enduring value to society.*

## INTRODUCTION

Whether your organization manages stand-alone or multiple projects, whether those projects are small or large, whether your customers are internal or external, or whether the nature of the work performed is product development, construction, design, IT, or service; most projects are difficult to manage because of two things:

- 1) They involve uncertainty, and
- 2) They involve three different and opposing commitments: Due date, budget, and content.

In organizations that attempt to manage multiple concurrent projects with common, shared resources, the job is even more challenging. Managers can quickly find themselves on “project overload” with continual resource shortages and great difficulty in determining which tasks are truly the most important.

If this is beginning to sound familiar, then you are probably experiencing some of these problems in your organization:

*What are some of AGI's customers using TOC Project Management for?*

- Design of Manufacturing Systems
- Internal SAP implementation
- Maintenance, Repair, and Overhaul (MRO)
- New product development
- Pipeline Management
- Production and Assembly
- Program Management
- Strategic Planning

- There are difficulties completing projects on time, within budget, and with full content.
- There is too much rework activity.
- Promised lead times are longer than desired.
- Existing project work is not complete before new projects require a shifting in priorities.
- Project Managers and Resource Managers have frequent conflicts about priorities and resource commitments.
- Problems in one project cascade into problems in other projects.
- Some projects are abandoned or completed without the organization gaining the promised benefit.
- The organization is too slow responding to important opportunities.

This paper provides a brief introduction to the basics of TOC Project Management, showing how the solution addresses the underlying root causes of the problems listed above. It is organized in the context of answering three very important questions:

1. “What To Change?”
2. “What To Change To?”
3. “How To Cause The Change?”

## THE MAIN ROOTS

### IDENTIFYING “WHAT TO CHANGE?”

*What types of organizations have completed AGI's TOC Project Management Expert Program?*

- Aerospace
- Automotive
- Consulting
- Construction
- Defense
- High-Tech
- Manufacturing
- Metals & Mining
- Semiconductor
- Telecommunications
- Universities and Colleges

In order to make significant and lasting improvements in the way projects are managed, an organization must effectively address the underlying root causes that lead to the above problems.

The dominant root cause in organizations performing multiple projects with shared resources is the unavoidable conflict about when to begin new project work. In almost every organization, there are continual internal and external pressures to address important new opportunities. At the same time, managers recognize that beginning new work too soon may divert needed resources from ongoing project work, compromising their ability to meet existing commitments. Unfortunately, with imperfect knowledge of the true status of current project work, ongoing pressures to increase the organization's output, and a belief that delaying a project's start will only serve to delay its finish, managers all too frequently make decisions that overload the organization.

The root cause that dominates the execution of individual projects is a planning and scheduling process that is based on several erroneous assumptions. One such assumption is the widespread belief that placing protection time in every task will lead to optimized project performance – that good individual task performance will inherently lead to good overall project performance. Couple this with the fact that today's most widely used scheduling algorithms don't provide proper protection for the effects of integrating pathways (many parallel paths of work, all of which must be completed before a common successor task may begin), don't correctly address resource dependencies, and don't properly account for task and iteration variability, and the stage is set for almost certain disaster (see figure 1). These algorithms calculate overly optimistic schedules that will almost certainly throw the project into expensive firefighting once it is recognized that the commitment is in serious jeopardy. Rushed up-front planning aggravates this situation by missing important task and resource dependencies.

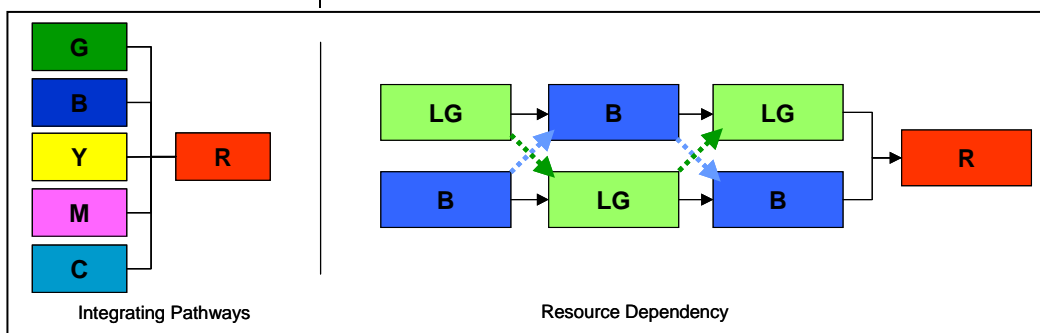

Figure 1. Today's widely used scheduling algorithms don't provide proper protection for the way in which projects are mapped.

Ultimately, firefighting becomes rampant, most people become severely multitasked, and management institutes coping mechanisms for more and more tracking of individual task and budget performance - ultimately resulting in more overhead and adding even more “protection time” to task estimates in an attempt to guarantee that people’s work will meet management’s expectations.

#### BEHAVIORAL REALITIES IN PROJECT ENVIRONMENTS

##### ADDITIVE RULE:

The commitments for duration and total cost of a project are based upon adding up the duration and cost of the individual tasks.

##### PARKINSON’S LAW:

Work expands to fill its time.

##### 3-MINUTE EGG RULE:

It’s not quality if it’s finished before the time is up.

##### STUDENT SYNDROME:

Waiting to start a task due to more important work at hand.

Under such circumstances, people begin to place a higher priority on self-preservation. Being measured on individual task performance, people realize that it is not in their best interest to report early finishes. They may feel it will compromise their future negotiations, or they may worry about being blamed for problems in their work because they did not take all the time they were given. More than likely, the task completion criteria are also very vague and people even feel encouraged to work well beyond what is truly *good enough*. At the same time, since most people carry such heavy loads, just the knowledge that the “protection time” is there makes them believe it is possible to use some of that time to finish other, more time-critical work.

The net result is that work that could have been turned in early is not, and the project has little chance to take advantage of any “positive variation.” The effect of late tasks accumulates day-by-day while any potential for early task completion is almost completely masked.

Unless these two major root causes are addressed effectively, there is little chance for any organization to make significant and lasting improvements in project management performance.

## THE SOLUTION FOR THE MAIN ROOTS IDENTIFYING “WHAT TO CHANGE TO?”

TOC Project Management provides a comprehensive solution to address these root causes and coping mechanisms. The solution includes (1) a robust planning process; (2) a more effective scheduling process; (3) a methodology for introducing work that actually leads to increased capacity; (4) execution processes that provide excellent project control, visibility, and decision support; and (5) work behaviors that are more conducive to good project performance.

### TOC Project Management: Project Planning

Project planning (called Network Building) begins with a combined meeting of project stakeholders to gain complete clarity on the intended objectives, deliverables, and success criteria of the project. This gets everyone on the same page at the earliest possible moment, identifies areas where more definition may be required, and typically prevents mid-project surprises and rework. This session also surfaces any constraints (boundary conditions) within which the project’s objectives must be accomplished.

In some engineering environments, a performance measurement baseline (PMB) is used to track technical performance in relationship to cost and schedule. Undistributed Budget is an element of the PMB. It is authorized work held at top level until it can be planned in detail.

In these environments, Network Building is critical in establishing the PMB, and therefore the Contract Budget Base. By gaining any needed insight and detail upfront, this process helps identify and assess risk early on in the program.

Starting with the project deliverables, the project network is constructed backwards in time with the participation of the project manager and key content experts. The process identifies the important task, path, and resource dependencies. Each individual task is defined in terms of its completion criteria and the resources and skills that will be required to accomplish it. This results in the same clarity of path identification as working a maze from its ending point, back toward its start, while ensuring the project work itself is planned to deliver the complete, necessary scope.

While constructing the project networks, the leader of the network building activity works with the content experts to define the minimum skills required for each task and identify the few tasks that truly need limited, specialist skills versus the many tasks that can be accomplished by lesser skilled personnel. This aids the reduction of resource dependencies within the project, which can reduce project cycle time. It also helps to reserve the highest skilled personnel for where they are truly needed.

Network Building differs from traditional planning by:

Building precedence:

- Necessity vs. Flow
- Starting Point
- Checks for missing dependencies

Capturing time estimates:

- Account for task and iteration variability
- Drive desired work behaviors

Once the resources and required skills are defined, the network building team estimates the potential variability associated with each task and the potential iteration variability associated with specific sequences of tasks. Each task is characterized in terms of a “highly probable” time to complete and an “aggressive but possible” time to complete.

A similar process is followed for identifying iteration variability. The team estimates a highly probable number of iterations that may be required for the appropriate task sequences. They also estimate an aggressive but possible number of iterations. Both task and iteration variability estimates feed into the scheduling process defined below.

In all, there are six independent safety nets in the TOC Project Management process of building project networks. People who follow the process rarely experience difficulties that can be traced back to faulty planning. In fact, the results of this process are frequently so dramatic that many users report this is the first time they have truly understood the work that needs to be done!

### **TOC Project Management: Project Scheduling**

Upon completion of the network building process, the resulting network is used to determine the project schedule with a process commonly called Critical Chain Scheduling.

Task, resource, and iteration dependencies are analyzed to determine the longest “chain of work,” called the Critical Chain. The process then separates what can be thought of as the “fixed” component of the work from the “variable” component of the work. The fixed component of each task (and each iteration sequence) is the aggressive but possible estimate.

The variable component (also called “safety”) is the difference between the aggressive but possible estimate and the corresponding highly probable estimate. This safety is then removed from each task location and aggregated with the safety from other tasks in the same chain of work. A portion of the aggregated safety is placed in strategic locations where it will serve to protect the project as a whole. These placements are called buffers.

A Project Buffer, located between the end of the Critical Chain and the project’s commitment date, protects the project from the effects of execution variability along the Critical Chain (see figure 2). Feeding Buffers, located every place a non-Critical Chain task feeds a Critical Chain task, protect the Critical Chain from execution variability along the paths that feed it.

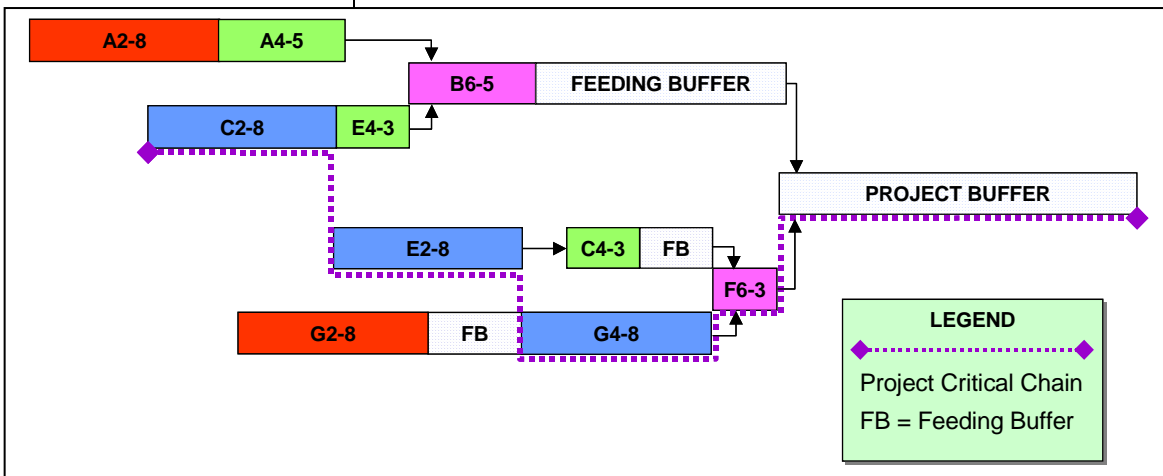

Figure 2. A simple project to illustrate the placement of time buffers.

The proper placement of safety protects project performance from the effects of task and path variability and signals the start of work at the appropriate time.

There are two places to protect:

*Due date* - from variability within the longest path of dependent events

*Longest path* - from variability of shorter paths that join it (integration)

The mathematical properties of aggregation, combined with new ways of working (see “Appropriate Work Behaviors” below) on project tasks, lead to a reduction in the total amount of safety that is required – much less than traditional methods would require to protect each task separately. This leads to shorter overall project duration and, in some cases, reduced project costs.

The resulting Critical Chain schedule is both feasible and immunized. *Feasible*, in that resource contention is properly accounted for and *immunized*, in that safety is placed in strategic locations where it will protect the project as a whole. The insertion of buffers also staggers path starts, leading to clearer priorities for resources, a reduction in the tendency for significant bad multitasking, and a reduced potential for mistakes.

### TOC Project Management: Synchronized Project Work Introduction

It turns out that just the act of introducing project work that exceeds the organization’s capacity will, in itself, lead to further capacity reductions because of increased bad multitasking. Instead, TOC Project Management

Some AGI customers that have applied TOC Project Management:

- Air Force Flight Test Center
- Air Force Operational Test & Evaluation Center (AFOTEC)
- Balfour Beatty
- BHP Copper
- CAE USA
- The Boeing Company
- EATON Corporation
- Eli Lilly and Company
- Fairchild Semiconductor
- F-22 System Program Office
- General Motors Corporation
- Herman Miller, Inc.
- Intel Israel – Platform Networking Group
- Israeli Air Force Material Management Division
- Lockheed Martin-Aero
- LSI Logic
- Lucent Technologies
- Seagate Technology
- Shea Homes
- Smiths Industries
- Synergis Technology
- Verhaert

TOC Project Management has a Budget Planning and Execution Process that complements Critical Chain.

pre-selects a more heavily loaded resource to serve as a gate for work release. New project work will be scheduled to begin in an interval of time where its need for that resource (Synchronizer) can be accommodated.

Projects must be scheduled and synchronized before a completion date can be committed. This way, commitments are made based on feasible, immunized schedules that are in alignment with the organization’s true capacity to accomplish its work. Although it seems counter-intuitive to what many have come to believe over the years, the staggering of work introduction actually increases an organization’s capacity and shortens overall project durations. More work can be accomplished in the same interval of time.

### TOC Project Management: Project Control and Impact Visibility

Project Control is accomplished through Buffer Management, which is a process of managing the aggregated safety that was placed between the final task of the Critical Chain and the project completion date. Delays along the Critical Chain consume Project Buffer time. Early finishes add to the Project Buffer.

Senior management typically watches Project (and Budget) Buffer performance versus progress along the Critical Chain. Functional (resource) managers assign resources to tasks, using the associated Project Buffer status to determine the relative urgency of the available tasks. Functional managers also use resource load profiles that highlight potential resource overloads early enough for effective and inexpensive resolution.

Project managers monitor their project status using Project Buffer and Critical Chain status. A *Planning Threshold* initiates their planning and an *Action Threshold* calls those plans into implementation. Most TOC Project Management software tools provide powerful “what-if” capabilities to assist project managers in their efforts to determine what actions will help them to recover a project with a collapsing Project Buffer.

Visibility to project status, visibility to current and future resource loading (see figure 3), and powerful “what if” analysis takes all the guesswork (and emotion) out of managing projects.

Senior managers, project managers, and resource managers have a clear and factual basis from which to make their decisions. This leads to shorter, more effective meetings that result in decisions that are more beneficial to good project performance.

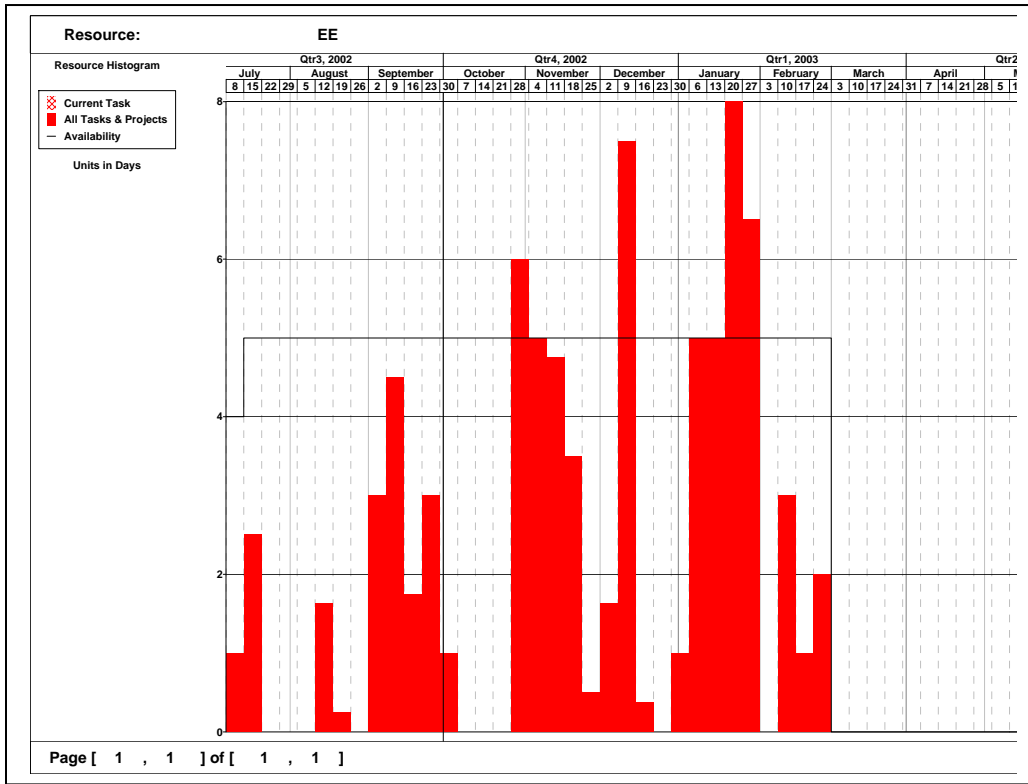
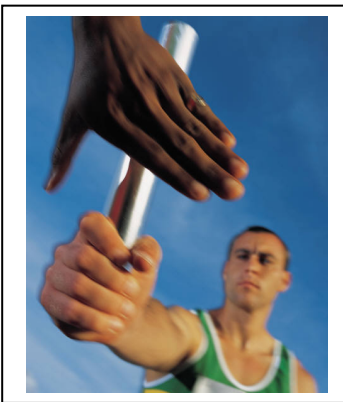

Figure 3. An illustration of a Resource Load Profile.

### TOC Project Management: Appropriate Work Behaviors

As discussed earlier, the coping mechanisms that managers put in place to deal with the variable nature of project work accomplish the exact opposite of what was intended – safety is placed everywhere and then wasted by the behaviors that people must adopt to protect themselves.



At the core of TOC Project Management is a work behavior called the Relay Runner work ethic. Briefly stated, this behavior calls for people to begin work as soon as they have been assigned to a task, to work continuously until the task's completion criteria have been met, and to provide immediate notification of that completion. The project network is based upon the aggressive but possible times, but people are held accountable only to the work behavior, not achieving the aggressive but possible task duration estimate. By its very definition, all concerned recognize that there is some probability that the aggressive but possible time can be beat, but also some probability that the time estimate cannot be met.

In most overloaded, heavily multitasked work environments, people are frequently shifted back and forth between tasks as priorities change. That unavoidably results in a large number of tasks being idle for significant amounts of time, essentially queuing to be worked on. People utilization is very high, probably too high. Task utilization is low, definitely too low. Suppose, for example, a person is given a ten-day task to do – one of the

many they are expected to perform simultaneously. Every other day, they get pulled off that task to do other, more urgent task work. That means the ten-day task will take 19 days to complete – 19 days of “elapsed time” to accommodate 10 days of “touch time.” If that task is on the longest path of the project, those 9 days of “task idle time” translate directly into a 9-day delay in project completion. The unfortunate thing is that, in many heavily multitasked work environments, overall “task idle time” is a depressingly large number.

The focus of change is typically on the new work process, the new technology, or the new strategy *rather than on the people who must implement change.*

*...We ignore the most important question of the three: How to cause the change?*

To make improvements, an organization must recognize the need for work behaviors to change and make it safe for people to resist unmerited requests for multitasking, to report early finishes, and to come forward to ask for help when they are stuck without fearing a lowered performance evaluation. This requires a significant shift in people’s thinking at all levels of the organization but, properly executed, delivers dramatically improved results.

### TOC Project Management: Summary of Benefits

#### TOC PROJECT MANAGEMENT SOLUTION ELEMENTS

**SYNCHRONIZATION MECHANISM** – Effectively handles the sequencing of committed and new projects

**PROJECT PLANNING** - Identifies the effects of dependencies and errors from time estimates

**PROJECT SCHEDULING** – Minimizes errors of the Additive Rule and prevents releasing work too early

**RESOURCE BEHAVIOR** – Encourages reporting of Early Finishes, identifies “gold-plating”, reinforces strict adherence to schedule and task

**PROJECT CONTROL and VISIBILITY** - Focuses on overall project performance instead of task and milestone performance

The network building process results in up-front agreement of all major stakeholders regarding important project objectives and deliverables, early identification of the key interdependencies that will dominate the project, clear task completion criteria, realistic resource needs, and a much more complete understanding of the project to be undertaken.

The project scheduling process yields a feasible, immunized schedule centered on a Critical Chain of work that will dominate the project throughout execution—a shorter, better protected schedule that is able to absorb many known and unknown risks. This allows project managers to focus on the critical few tasks, separated from the important many.

The synchronization of a portfolio of projects around a more heavily loaded resource staggers competing concurrent project demands on all resources, aligning project work to the organization’s true capacity to handle the work. This enables the organization to make realistic

commitments that can be reliably met. Projects are accomplished in less time – starting later than they normally would using traditional methods yet finishing earlier. Managers also have a tool for assessing the impact of any major changes on the entire portfolio.

The project control mechanisms, such as Buffer Management, provide a clear indication of the health of each project. This, in turn, provides a sound basis for prioritizing the tasks for resource assignment. For the first time, managers have a tool that allows them to always assign their people

to the task work that will benefit the organization most. Because project managers are able to focus in the right places and quickly determine recovery plans, project management becomes more proactive and less reactive, with a dramatically increased ability to meet schedule, cost, and scope commitments without crisis spending.

The new work behaviors ensure high resource productivity, high task productivity, improved overall project performance, and a much higher quality of work life.

## PUTTING THE SOLUTION INTO PLACE IDENTIFYING “HOW TO CAUSE THE CHANGE?”

For many organizations, projects are “what we do for a living.” *Projects are their business.* In such environments, changing how people manage projects is tantamount to changing the basic fabric of the business. Clearly, one must approach such change with great care. The right people must be

brought into the picture at the right time, in just the right way. The process must move slowly enough to permit identification of essential changes, yet fast enough that it does not lose the momentum that is necessary to sustain continued progress. The Goldratt Institute has developed a very robust implementation process consisting of six distinct phases. Each phase builds upon the next and each is specifically designed around a logical progression of obtaining the true support and collaboration of the participants.

In the first phase, senior management learns what changes are required and what their roles need to be in facilitating that change. In order for change to succeed, they need to be in consensus that they will continue to champion the change for the long term.

Once they are aligned, management needs to inform the organization about what will change, why the change is necessary, how the organization and each of its people will benefit, and when and how they will be “brought on board.” Following the informational briefing, the hard work begins.

### The 6 Steps to Achieving Buy-In

- Step 1:** Secure agreement on the problem to be solved.
- Step 2:** Secure agreement on the direction of a solution.
- Step 3:** Verify that the proposed solution will deliver the desired results.
- Step 4:** Ensure that all significant potential negative side effects have been identified and prevented from happening.
- Step 5:** Identify and address all significant potential obstacles that could block implementation of the solution.
- Step 6:** Ensure that all the necessary leadership is committed to making the implementation successful.

There is a third phase, where previously trained experts begin to use the generic solution to identify areas where customization will be required to address the unique needs of the organization. In order to minimize disruption to the organization, only a few necessary people are brought into the activities of this phase.

### TOC Project Management Solution

For organizations and project managers who are working to improve their ability to continually meet the three seemingly illusive project commitments — budget, time, and content, the TOC Project Management Solution provides a comprehensive tool set that addresses:

- The nature of project planning
- Project scheduling
- Resource behavior
- Project visibility and control
- Multiple project synchronization

---

### TOC Supply Chain Management Solution

For supply chain, plant operations and distribution managers who are dealing with the challenges of ensuring availability of the right products at the right place and time — while maintaining profitable operations, TOC Supply Chain Management enables the organization to:

- Rapidly respond to actual market demand.
- Improve on-time deliveries.
- Reduce the need for overtime and expediting.
- Better utilize capacity to meet customer expectations.

During the fourth phase, the rest of the organization is brought into the picture. People are trained and begin to participate in their designated roles. This is also the phase where the readiness of all support systems is verified.

The fifth phase is more of an event than a phase of significant time duration. It is analogous to “throwing the switch” to take the system “live.” This is the point at which TOC Project Management truly becomes the “way we do our work.” If everything has been done properly up to that point, much of the chaos has now been driven out of the organization, setting up the final stage.

The sixth phase begins the process of ongoing improvement. At this stage, the organization has so much visibility to every aspect of its project management system that people can begin to systematically pinpoint and implement changes that will bring the most improvement to the bottom line.

Copyright ©1996-2009 Avraham Y. Goldratt Institute, LP. All rights reserved.

For more information regarding the  
AGI - Goldratt Institute’s course offerings, products, or  
services, please contact us at +1.800.394.GOAL (4625), or  
+1.203.624.9026.

Visit us at [www.goldratt.com](http://www.goldratt.com)

Avraham Y. Goldratt Institute, LP  
442 Orange Street  
New Haven, Connecticut  
06511 USA  
e-mail: [agi@goldratt.com](mailto:agi@goldratt.com)